

## Frequency Comparison and Optimization of Forged Steel and Ductile Cast Iron Crankshafts

K. Thriveni<sup>1</sup>, Dr. B. Jaya Chandraiah<sup>2</sup>

(<sup>1</sup> M. Tech Student, Department of Mechanical Engineering )

(<sup>2</sup> Vice-principal & Department of the Mechanical Engineering )

Srikalahasteeswara Institute of Technology, Srikalahasti, chittoor ,Dt, A.P

---

**ABSTRACT:** The crankshaft is part of an engine that converts reciprocating linear piston motion into rotation. The increased demand for improved performance and reduced cost in engines has led to significant competition in engine component materials and manufacturing process technologies. High strength, ductility, and fatigue resistance are critical properties required from the crankshaft material and manufacturing process. An attempt made in this paper to find the natural frequency for single cylinder 4-stroke I.C engine crankshaft and to optimization of crankshaft using modal analysis for two different materials such as cast-iron and forged steel. The Three Dimensional modelling and analysis of crank shaft are done by using CATIA-V5 Software and applying the boundary conditions. Then it is observed from the results Natural frequency for ductile cast-iron material in 1st mode is 890.735 Hz, 2nd mode is 990.53 Hz, 3rd mode is 1450.168Hz, 4th mode is 2413.328 Hz and 5<sup>th</sup> mode is 2623.305 Hz and for forged-steel material in 1st mode is 931.808 Hz, 2nd mode is 1036.66 Hz, 3rd mode is 1510.865 Hz, 4<sup>th</sup> mode is 2521.353 Hz and 5th mode is 2741.032 Hz. Then it is observed from CATIA-V5 Software the weight of ductile cast iron crankshaft is 3.063kg and the weight of forged steel crankshaft is 3.333kg. From the literature review Ref(5) the weight of ductile cast iron crankshaft is 3.58kg and the weight of forged steel crankshaft is 3.80kg. Therefore Optimization of Weight reduction in ductile cast iron and forged steel crankshaft are 0.517kg, 0.467 kg respectively and also in term of the percentage of weight reduction in ductile cast iron and forged steel crankshaft are 15% & 14%.

**KEY-WORDS:** Catia-v5. Natural frequency, Crankshaft.

---

### I. INTRODUCTION

The crankshaft is part of an engine that converts reciprocating linear piston motion into rotation. The crankshaft is often connected to the flywheel thus reducing the pulsation of the four-stroke cycle. In some recent models, the crankshaft is attached to the crankshaft sensor. Crankshafts are high volume production engine components and their most common application is in an automobile engine. Power from the burnt gases in the combustion chamber is delivered to the crankshaft through the piston, piston pin and connecting rod. The crankshaft changes reciprocating motion of the piston in cylinder to the rotary motion of the flywheel. Conversion of motion is executed by use of the offset in the crankshaft. Each offset part of the crankshaft has a bearing surface known as a crank pin to which the connecting rod is attached. Crank-through is the offset from the crankshaft centre line. The stroke of the piston is controlled by the throw of the crankshaft. The combustion force is transferred to the crank-throw after the crankshaft has moved past top dead centre to produce turning effort or torque, which rotates the crankshaft. Thus all the engine power is delivered through the crankshaft. The cam-shaft is rotated by the crankshaft through gears using chain driven or belt driven sprockets. The cam-shaft drive is timed for opening of the valves in relation to the piston position. The crankshaft rotates in main bearings, which are split in half for assembly around the crankshaft main bearing journals. Modal analysis is the study of the dynamic properties of structures under vibrational excitation. Modal analysis is the field of measuring and analysing the dynamic response of structures and or fluids when excited by an input. The goal of modal analysis in structural mechanics is to determine the natural mode shapes and frequencies of an object or structure during free vibration.

### II. LITERATURE REVIEW

B.D.N S Murthy et al [1] performs the Modeling, analysis and optimization of crankshaft. The analysis is done on two different materials there are Annealed 4340 steel, Inconel x750 alloy. The model were created in catia-v5 and the analysis is to be done in Ansys. The results are in strength point of view Inconel x750 is better than Annealed 4340 steel for crankshaft. P. Anitha, Baswaraj Hasu [2] have been described the solid modeling of 4-cylinder crankshaft and its frequency analysis. In this paper design and analysis of crankshaft using CATIA software. Then conclude the maximum deformation appears at the center of crankpin neck surface, the edge of main journal is high stress area. Whereas frequency analysis provides an overestimate results are occurred.

R.J.Deshbhratar, Y.R Suple [3] has been described Analysis and Optimization of crankshaft using FEM. The analysis was done on two different materials which are based on their composition. The model of crankshaft using PRO-E and the analysis was done using ansys. The results would provide a valuable theoretical foundation for the optimization and improvement of engine design. Mr.S.J. Patil et al [4] have been described the analytical and FE modal analysis of a crankshaft. The 3-Dimensional model were constructed in pro/E and the analysis has to be done in ansys. Crankshaft considered as two rotor system to calculate the six modes of frequency. The results show that the crank shaft is not running in critical speed.

### III. OBJECTIVE

An attempt made in this paper to find the natural frequency for single cylinder 4-stroke I.C engine crankshaft and to optimization of crankshaft using modal analysis for two different materials such as cast-iron and forged steel. The Three Dimensional modelling and analysis of crank shaft are done by using CATIA-V5 Software.

### IV. MODELING AND ANALYSIS OF CRANKSHAFT

Modelling is a pre-processor tool, the modelling of crankshaft are created using the Computer aided three-dimensional interactive application (Catia) V5 software tool. The geometrical module of the crankshaft is created using CATIA V5 software, CATIA is a pre-processor where the solid geometry is created using 2-D drawings, module created in CATIA is exported as IGES file for the next pre-processor for meshing. Meshing can be defined as the process of breaking up a physical domain into smaller sub-domains (elements) in order to facilitate the numerical solution of a partial differential equation.

Configuration of the Engine to which the crankshaft belongs, Fazin H. Montazersadgh and Ali Fatemi [5].

Crank pin radius	22.6
Shaft Diameter	34.925
Thickness of the Crank web	21.336
Bore diameter	53.73
Length of the crank pin	43.6
Maximum pressure	35bar
Connecting rod length	120.78
Distance of C.G of connecting rod from crank end centre	28.6

Table1: Dimensions of crankshaft

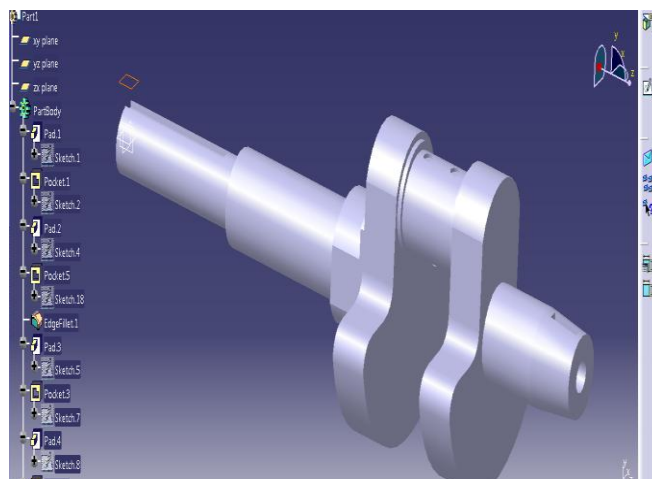


Fig: 1: 3-Dimensional model of the crankshaft

**Boundary conditions of crankshaft:**

Properties	Cast-iron	Forged steel
Young's modulus	$1.7e^{+011} \text{N/m}^2$	$2e^{+011} \text{N/m}^2$
Poisson's ratio	0.291	0.3
Density	$7197 \text{kg/m}^3$	$7833 \text{kg/m}^3$
Coefficient of thermal expansion	$1.2e^{-005} \text{k-deg}$	$1.17e^{-005} \text{k-deg}$
Yield strength	$3.1e^{+008} \text{N-m}^2$	$2.5e^{+008} \text{N-m}^2$

Table 2: Boundary conditions of the crankshaft

**V. RESULTS AND DISCUSSION**

The results of crankshaft on free-frequency and frequency (modal analysis) by using CATIA-V5 Software, the results are tabulated below.

**Case-1: Free-frequency case: (Cast-iron):** In free-frequency case there is no boundary conditions are applied in the crankshaft . In natural free-frequency the crankshaft should not be vibrating but some period of time vibrations are occurred because self weight of the crankshaft. The frequency occurred in 7<sup>th</sup> node . These frequency is known as resonance frequency .

S.No	MODE	FREQUENCY [Hz]
1	1-5	0
2	6	4.801e-004
3	7	1150.96
4	8	1370.633
5	9	2275.472
6	10	2435.688

Table:1 free-frequencies of vibration

**First Mode of vibration:**

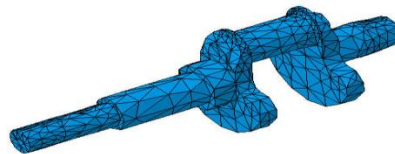


Fig: 3 First mode of vibration

The First mode to fifth mode there is no vibration occurring in the model.

**Seventh Mode of vibration:**

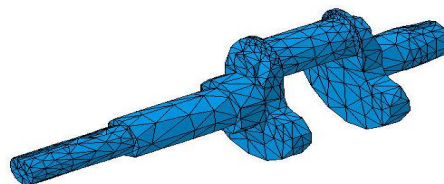


Fig: 4: 7<sup>th</sup> mode of vibration

The seventh mode of vibration is bending vibration, the natural frequency is 1150.96Hz.

**8<sup>th</sup> Mode of vibration:**

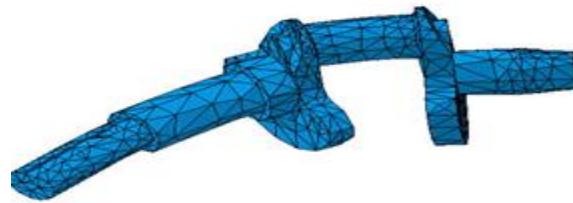


Fig:5: 8<sup>th</sup> mode of vibration

The eighth mode of vibration is occurred at the crankpin area .the frequency will be 1370.633Hz.

**9<sup>th</sup> mode of vibration:**

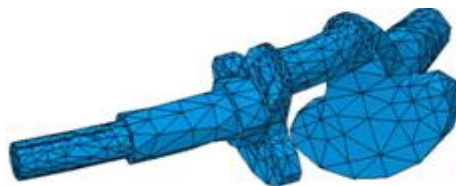


Fig: 6: 9<sup>th</sup> mode of vibration.

The ninth mode of vibration is occurred at the right side shaft part and the right side web part, the frequency is 2275.472Hz.

**10<sup>th</sup> mode of vibration:**

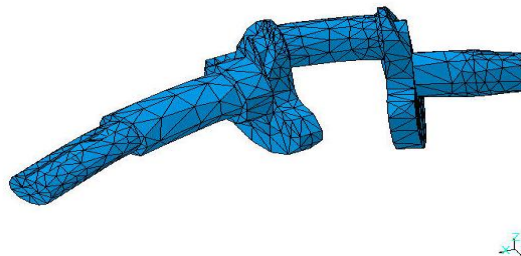


Fig: 7: 10<sup>th</sup> mode of vibration.

The 10<sup>th</sup> mode of vibration is bending vibration of crank pin area and the left side of the crank part , the frequency is 2435.688Hz.

**Frequency case :**

In frequency case applied boundary conditions on the crankshaft, the two ends of the crankshaft is to be fixed at the shaft part and the bearing load applied on the crankpin area.

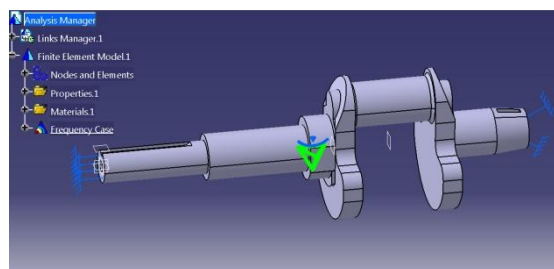


Fig: 8 boundary conditions applied on the crankshaft

MODE	FREQUENCY [Hz]
1	890.735
2	990.53
3	1450.168
4	2413.328
5	2623.305
6	3035.357
7	3623.042
8	4678.819
9	5480.648
10	5539.023

Table:2 natural frequency case

**First mode of vibration:**



Fig: 9 First mode of vibration

The first mode of vibration in x-direction at natural frequency of 890.735Hz Translation in y-axis is 77.37% , rotation in x& z directions is 0.73% &0.22%.The maximum frequency appears at the bottom of the crank web.

**Second mode of vibration**

The second mode of vibration in y-direction is 990.53Hz. Translation in x-direction is 0.27% and y-direction is 78.11% , rotation in x-direction is 0.45. The maximum frequency appears at the left web and the left side of the shaft part.

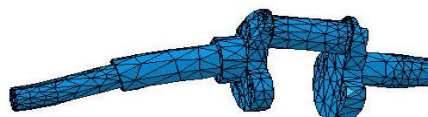


Fig:10 second mode of vibration.

**Fifth mode of vibration:**

The fifth mode of vibration in y-direction is 2623.3Hz. Translation in x-direction is 7.66% and x-direction is 1.51% , rotation in y-direction is 5.79%. The maximum frequency appears at the side of the crank web.



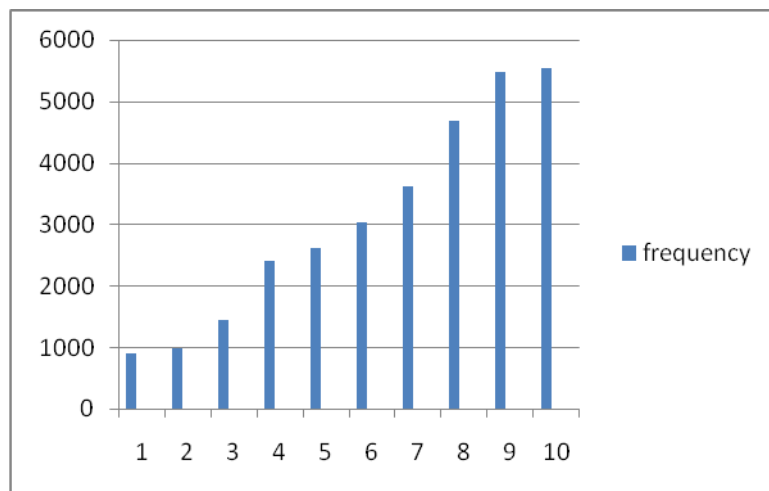
Fig: 11- fifth mode of vibration

**10<sup>th</sup> mode of vibration:**

The 10<sup>th</sup> mode of vibration in frequency is 5539Hz. Translation in x-direction is 13.69% and z-direction is 4.32% , rotation in y-direction is 1.44%. The bending occurred at the right side of the crank web,since the crankshaft has increase the no.of revolutions the force applied on the crankshaft wii be increased so that the frequency is also increased the bending of the crank web occurred.

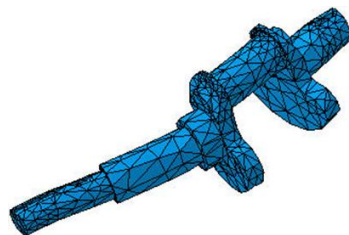


Fig: 12: 10<sup>th</sup> mode of vibration



Graph:1 Modal graph for cast-iron

**frequency case (Forged steel):**



**First mode of vibration:**

Fig: 13: first mode of vibration

The first mode of vibration in y-direction at natural frequency of 931.81Hz Translation in y-axis is 77.02% , roation in x-directions & z-direction is 0.79 % & 0.23. The maximum frequency appears at the bottom of the crank web. The maximum bending occurs at the left shaft part.

**Second mode of vibration:**

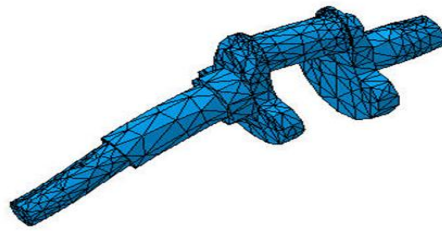


Fig: 14: second mode of vibration

The second mode of vibration in z-direction at natural frequency of 1036.7Hz Translation in z-axis is 77.87% . The maximum bending occurs at the left shaft part.

**Third mode of vibration**

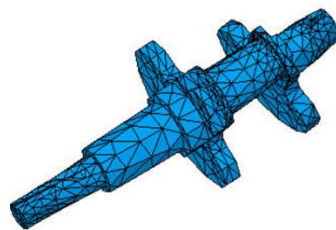


fig: 15: third mode of vibration

The third mode of vibration in natural frequency of 1510.9Hz .rotation in z directions is 90.06%.The maximum frequency appears at the right shaft part and right crankweb.

**Fourth mode of vibration:**

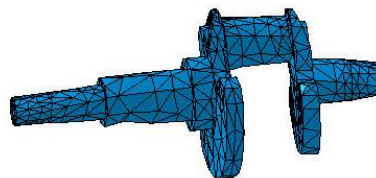


Fig: 16: fourth mode of vibration

The fourth mode of vibration in y-direction at natural frequency of 2521.4Hz .Translation in y-directions is 4.88%. Rotation in x& z is 6.27% &4.37%. The maximum frequency appears at the left side crank web .

**Tenth mode of vibration:**

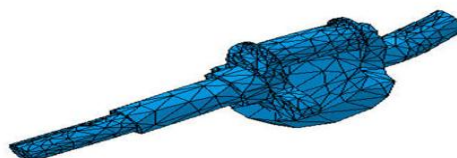
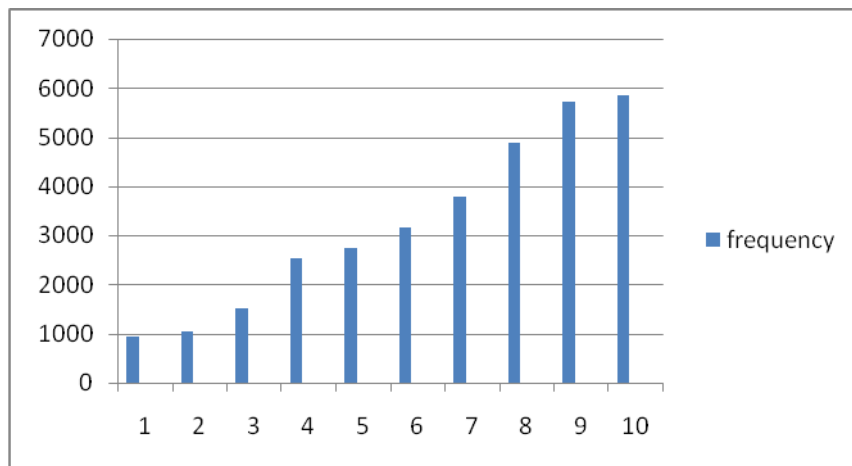


Fig: 17: tenth mode of vibration

The tenth mode of vibration in x-direction at natural frequency of 5855Hz .Traslation in x-direction, y-direction is 14.87%,4.87%. Rotation in y-direction is 1.26%.The maximum frequency appears at the right side of the crank web and the bending moment appers at the right side of the shaft part.

MODE	FREQUENCY Hz
1	931.808
2	1036.66
3	1510.865
4	2521.353
5	2741.032
6	3157.903
7	3790.403
8	4896.67
9	5711.606
10	5855.942

Table: 3 Frequency case



Graph 2: Modal graph for forged steel

## VI. CONCLUSION:

- In free-frequency case the resonance frequency is 1150.967Hz at 7<sup>th</sup> mode. When the engine running at the high speed, the driving frequency is merely 100Hz. As the lowest natural frequency is far higher than driving frequency, possibility of resonance is rare.
- In Cast-iron material the frequency lies between 890.735Hz to 5539.023Hz.
- In Forged-steel material the frequency lies between 931.808Hz to 5855.942Hz.
- The cast iron crankshaft weight as measured on a weighing scale is 3.58kg [5]. The weight of the modelled cast-iron crankshaft is 3.063kg, reduction in mass is 0.517kg, the percentage of weight reduction is 15%.weight of the forged steel crankshaft is 3.80kg. The weight of the modelled forged steel crankshaft is 3.333kg, reduction in mass is 0.467kg and the percentage of weight reduction is 14%.

## REFERENCES:

- [1] BDNS Murthy “ Modeling analysis and optimization of crankshaft”, vol-2, Issue-9, ISSN: 2278-0181, Pages: 749-753, September-2013.
- [2] P.Anitha, Baswaraj Hasu “ Solid Modeling of 4-cylinder crankshaft and its frequency analysis using CATIA”, International Journal of reaserch in Engineering & Advanced Technology, Volume-1, Issue: 4, ISSN No: 2320-8791, Pages: 1-4, Aug-Sep 2013.
- [3] R.J Deshbharatar, Y.R.Suple “ Analysis & optimization of crankshaft using FEM”, International Journal of modern engineering reaseach, Vol-2, Issue: 5, ISSN No: 2249-6645, Pages: 3086-3088, Sep 2012.
- [4] Mr.S.J.Patil “ Modal analysis of compressor crankshaft” International Journal of Scientific Reasearch, Vol-2, Issue-7, ISSN No: 2277-8179, Pages: 155-158, July-2013.
- [5] Farzin H. Montazersadgh and Ali Fatemi “ Stress Analysis and Optimization of Crankshafts Subjected to Dynamic Loading”, AISI, August 2007.